

PSCAD/EMTDC BASED SIMULATION OF DOUBLE FED INDUCTION GENERATOR FOR WIND TURBINES

Farhad Shahnian¹, Mohammad B.B. Sharifian²

¹ East Azarbayjan Electric Power Distribution Company, Tabriz, Iran

² Faculty of Electrical and Computer Engineering, University of Tabriz, Tabriz, Iran
farhadshahnian@yahoo.com, sharifian@tabrizu.ac.ir

Abstract. In this paper, a DFIG power conversion system is simulated and vector controlled for improving power quality of the grid while injecting the required active power of the system. The system model proposed in this paper is developed in the dedicated power electronics and system simulation tool, PSCAD/EMTDC. The model also includes dynamic wind speed fluctuations and control of a soft starter, enabling simulation of the power quality characteristics of the wind turbine. Based on the simulation results, it is proved that the proposed DFIG is capable of simultaneous capturing maximum power of wind energy with fluctuating wind speed and improving power quality, that are achieved by cancelling the most significant and troublesome harmonics of the utility grid. Dynamic power factor correction and reactive power control are the other two significant features of this technology.

Keywords. Double Fed Induction Generator, Wind turbines, Modeling, Vector control

1. INTRODUCTION

Wind Energy is a very promising energy for the future. One of the most significant problems in this way is the low power quality problem due to the installation of wind turbines. It is well known that the power delivered by wind turbines directly coupled to the grid is not constant as a result of the wind variability. In the absence of storage systems, a fluctuating power supply produced, can lead to voltage variations in the grid and flicker. Another disadvantage of most induction machines utilized in the wind turbines is that the required reactive power varies with wind speed and time. These problems can make the use of double fed induction generators attractive for wind turbine applications.

Double fed induction machines using an AC-AC converter in the rotor circuit have long been a standard drive option for high power applications involving a limited speed range. The power converter need only be rated to handle the rotor power. Wind energy generation is regarded as a natural application for the DFIG system, since the speed range may be considered restricted. Most DFIGs use either a current fed DC Link converter or cycloconverter in the rotor circuit. The rated speed settings, gearbox ratios, and machine and converter ratings and the output power of the DFIG have been studied previously. The use of a current fed DC link converter has a number of disadvantages such as the high costs of the DC link and the necessity of an extra commutation circuit for operation at synchronous speed and this has resulted in poor performance at low slip speeds. In addition, such a converter draws rectangular current waveforms from the supply. The problem at synchronous speed may be overcome by use of a cycloconverter or vector controlled DFIGs. The disadvantages of the naturally commutated DC link and cycloconverter can be overcome by the use of two PWM voltage fed current regulated inverters that are connected back-to-back in the rotor circuit. The characteristics of such a DFIG scheme with both vector controlled converters are as follows:

- Operation below, above and through synchronous speed with the speed range restricted only by the rotor voltage ratings of the DFIG
- Operation at synchronous speed, with DC currents injected into the rotor with the inverter working in chopping mode
- Low distortion stator, rotor and supply currents independent control of the generator torque and rotor excitation
- Control of the displacement factor between the voltage and the current in the supply converter, and hence control over the system power factor

In this paper, a DFIG power conversion system is simulated and vector controlled for improving power quality of the grid while injecting the required active power of the system. The system model proposed in this paper is developed in the dedicated power electronics and system simulation tool, PSCAD/EMTDC. Based on the simulation results, it is proved that the proposed DFIG is capable of simultaneous capturing maximum power of wind energy with fluctuating wind speed and improving power quality, that are achieved by cancelling the most significant and troublesome harmonics of the utility grid. Dynamic power factor correction and reactive power control are the other two significant features of this technology.

2. MACHINE DESCRIPTION AND EQUATIONS

The double fed induction generator allows power output into the stator winding as well as the rotor winding of an induction machine with a wound rotor winding. Using such a generator, it is possible to get a good power factor even when the machine speed is quite different from synchronous speed.

The stator of the wound rotor induction machine is connected to the low voltage balanced three-phase grid and the rotor side is fed via the back-to-back IGBT voltage-source inverters with a common DC bus. The front-end converter controls the power flow between the DC bus and the AC side and allows the system to be operated in sub-synchronous and super synchronous speed. The vector control strategy of the power converter is based on the stator flux field oriented control which both fundamental and harmonics currents are controlled. It is assumed that the total harmonics currents demanded by nonlinear loads connected to the utility are either sampled through current measurements. This makes the command harmonics current for rotor side power converter. The active power is generated in regard to wind speed and wind turbine characteristics while the reactive power command is set in regard to the utility demand. The proper rotor excitation is provided by the rotor side power converter. The fundamental current controls the active and reactive powers. So, the utility current will be a pure sine wave. Decoupled control of the active and reactive powers and harmonic compensation are implemented. The schematic diagram of a double fed induction generator for wind turbine application is shown in Fig. 1.

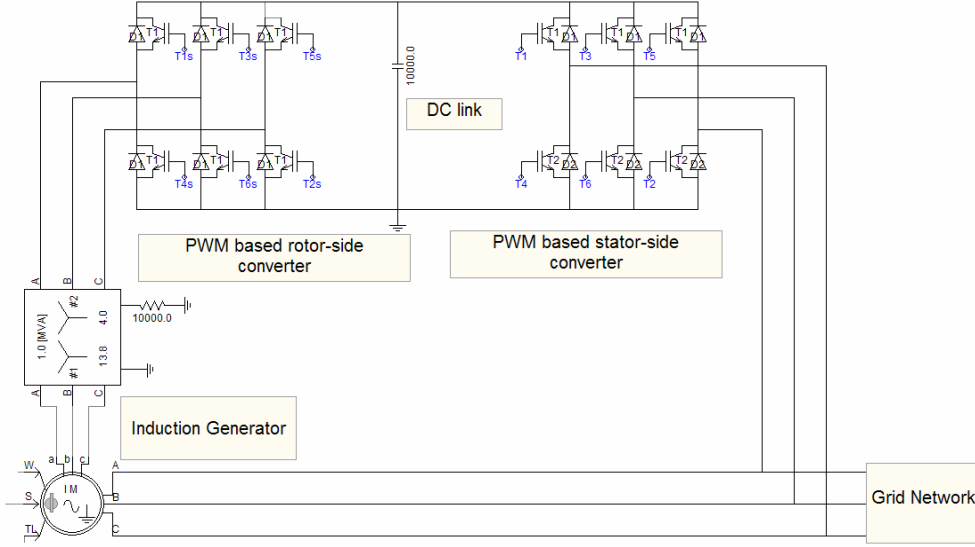

Fig. 1. Schematic Structure of DFIG application for wind turbines simulated in PSCAD/EMTDC

The equivalent circuit of a double fed induction generator is shown in Fig. 2 from which the model equations in a constantly, with ω_{ref} rotating reference frame can be delivered as follows:

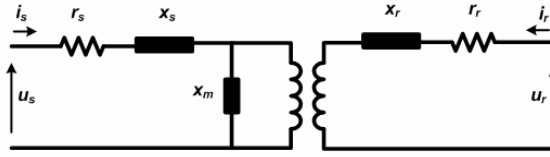

Fig. 2. Equivalent circuit of a DFIG

$$u_{s\alpha}^k = r_s \cdot i_{s\alpha}^k + \frac{1}{\omega_n} \frac{d(\psi_{s\alpha}^k)}{dt} - \frac{\omega_{ref}}{\omega_n} \cdot \psi_{s\beta}^k \quad u_{s\beta}^k = r_s \cdot i_{s\beta}^k + \frac{1}{\omega_n} \frac{d(\psi_{s\beta}^k)}{dt} - \frac{\omega_{ref}}{\omega_n} \cdot \psi_{s\alpha}^k \quad (1)$$

$$u_{r\alpha}^k = r_r \cdot i_{r\alpha}^k + \frac{1}{\omega_n} \frac{d(\psi_{r\alpha}^k)}{dt} - \frac{\omega_{ref} - \omega_g}{\omega_n} \cdot \psi_{r\beta}^k \quad u_{r\beta}^k = r_r \cdot i_{r\beta}^k + \frac{1}{\omega_n} \frac{d(\psi_{r\beta}^k)}{dt} - \frac{\omega_{ref} - \omega_g}{\omega_n} \cdot \psi_{r\alpha}^k \quad (2)$$

where the flux linkage can be expressed by the following equation:

$$\psi_{s\alpha}^k = x_s \cdot i_{s\alpha}^k + x_h \cdot i_{r\alpha}^k \quad \psi_{s\beta}^k = x_s \cdot i_{s\beta}^k + x_h \cdot i_{r\beta}^k \quad (3)$$

$$\psi_{r\alpha}^k = x_h \cdot i_{r\alpha}^k + x_r \cdot i_{r\alpha}^k \quad \psi_{r\beta}^k = x_h \cdot i_{r\beta}^k + x_r \cdot i_{r\beta}^k \quad (4)$$

The induction machine model is completed by the mechanical Eq. 5.

$$J \frac{d\omega_g}{dt} = t_m + t_{el} \quad (5)$$

where the mechanical and electrical torque formula as T_m and T_e can be calculated respectively by:

$$T_m = \psi_{s\alpha}^k \cdot i_{s\beta}^k - \psi_{s\beta}^k \cdot i_{s\alpha}^k \quad (6)$$

$$T_e = \text{Im}(\psi_{s\alpha}^k \cdot i_{s\beta}^{k*}) \quad (7)$$

where all the equations above are described in stator side perunit system.

Two voltage fed PWM converters are inserted in the rotor circuit, with the supply-side PWM converter connected to the stator supply. The voltage-transfer characteristics of the system, including the three-phase back-to-back PWM converters, are calculated by:

$$V_s = m_1 \frac{\sqrt{3}E}{2\sqrt{2}} \quad V_r = \pm s \cdot \frac{V_s}{n} = m_2 \frac{E}{2\sqrt{2}} \quad (8)$$

where n is the turns ratio of stator to rotor of the DFIG, s is the slip and m_1 and m_2 are the PWM modulation depths of the stator and rotor side converters, respectively. Eq. 1 determines the speed range of the generator. For wind generation, a restricted speed range is acceptable on account of a minimum wind velocity. The generator speed corresponding to rated wind velocity can be set at any point by means of the gearbox ratio. But this point should be well above synchronous speed where power is extracted from both the rotor and stator of the machine for making more benefit out of this structure. Eventually, however, as the slip is increased, the system efficiency starts to decrease since more power passes through the DC link converters and the rotor losses increase.

The general space vector equivalent circuit for DFIG at steady state for the fundamental voltage is shown in Fig. 3. The harmonic equivalent circuit of DFIG directly connected to the grid with a sinusoidal voltage waveform for it for the harmonic slip of n is denoted as S_n and is defined by:

$$S_n = \frac{\omega_n - \omega_r}{\omega_n} \quad (9)$$

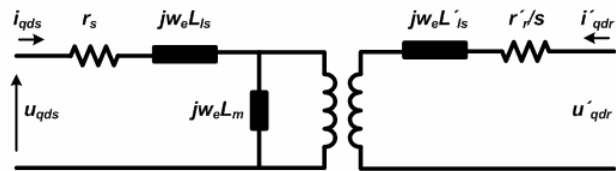

Fig. 3. General space vector equivalent circuit for DFIG

The harmonic equivalent circuit of the compensation system is shown in Fig. 4 where v_{rn} is the amplitude of harmonic n of rotor side power converter output voltage and the nonlinear load is modeled as current source with magnitude of I_{ln} . The equivalent circuit of the grid consists of a series resistor R_e and reactance of $X_e = n\omega_e L_e$ for a pure sinusoidal voltage waveform.

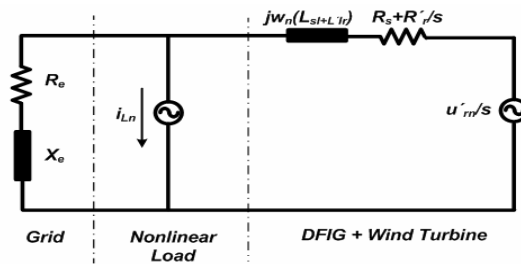

Fig. 4. Harmonic equivalent circuit of the compensation system

The rotor currents (i_{ra}, i_{rb}, i_{rc}) of the machine can be resolved into the well known direct and quadrature components i_d and i_q . The component i_d produces a flux in the air gap which is aligned with the rotating flux vector linking the stator; whereas the component i_q produces flux at right angles to this vector. The torque in the machine is the vector cross product of these two vectors, therefore, only the component i_q contributes to the machine torque and power. The component i_d controls the reactive power entering the machine. If i_d and i_q can be controlled precisely, then the stator side active and reactive powers are controlled correctly.

The induction machine is controlled in a synchronous rotating dq axis frame, with the d-axis oriented along the stator-flux vector. In this way, a decoupled control between the electrical torque and the rotor excitation current is obtained. The rotor side PWM converter provides the actuation, and the control requires the measurement of the stator and rotor currents, stator voltage and the rotor position. Since the stator is connected to the grid and the influence of the stator resistance is small, the stator magnetizing current can be considered constant. Under stator-flux orientation, the relationship between the torque and the dq axis voltages, currents and fluxes per-phase values are calculated by:

$$\begin{aligned}
 \lambda_s &= \lambda_{ds} = L_o \cdot i_{ms} = L_s \cdot i_{ds} + L_o \cdot i_{dr} & v_{dr} &= R_r \cdot i_{dr} + \sigma \cdot L_r \cdot \frac{di_{dr}}{dt} - \omega_{slip} \cdot \sigma \cdot L_r \cdot i_{qr} \\
 \lambda_{dr} &= \frac{L_o^2}{L_s} \cdot i_{ms} + \sigma \cdot L_r \cdot i_{dr} & v_{qr} &= R_r \cdot i_{qr} + \sigma \cdot L_r \cdot \frac{di_{qr}}{dt} + \omega_{slip} \cdot (L_m \cdot i_{ms} + \sigma \cdot L_r \cdot i_{dr}) \\
 \lambda_{qr} &= \sigma \cdot L_r \cdot i_{qr} & T_e &= -3 \frac{P}{2} L_m \cdot i_{ms} \cdot i_{qr} \\
 i_{qs} &= -\frac{L_o}{L_s} \cdot i_{qr} & L_m &= \frac{L_o^2}{L_s} \\
 \omega_{slip} &= \omega_e - \omega_r & \sigma &= 1 - \frac{L_o^2}{L_s \cdot L_r}
 \end{aligned} \tag{10}$$

And the stator flux angle is calculated from:

$$\lambda_{\alpha s} = \int (v_{\alpha s} - R_s \cdot i_{\alpha s}) \cdot dt \qquad \lambda_{\beta s} = \int (v_{\beta s} - R_s \cdot i_{\beta s}) \cdot dt \qquad \theta_s = \text{tg}^{-1} \frac{\lambda_{\beta s}}{\lambda_{\alpha s}} \tag{11}$$

The schematic diagram of an induction machine connected to the wind turbine is shown in Fig. 5.

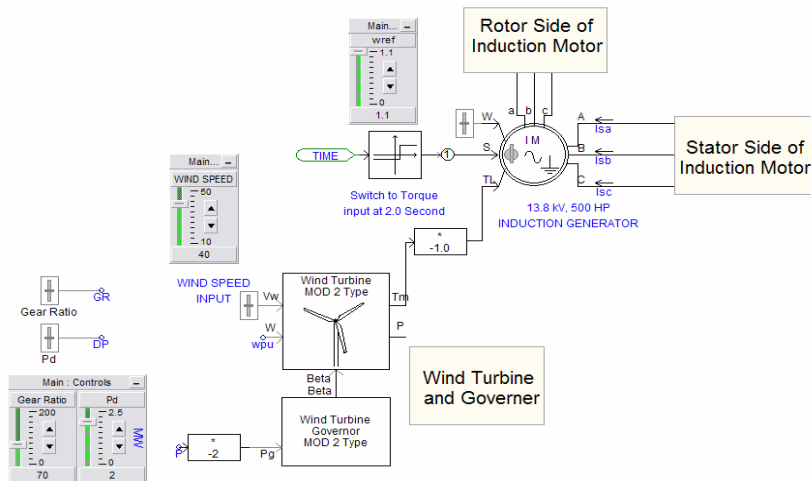

Fig. 5. Schematic of DFIG for wind turbine application

3. MACHINE AND CONVERTER CONTROL METHOD

The procedure for ensuring that the correct values of i_d and i_q flow in the rotor is achieved by generating the corresponding phase currents references i_{ra_ref} , i_{rb_ref} and i_{rc_ref} and then using a suitable current source as a voltage sourced converter to force these currents into the rotor. Then a current reference PWM technique should be applied. The crucial step is to obtain the instantaneous position of the rotating flux vector in space in order to obtain the rotating reference frame. This can be achieved since the stator voltage after subtracting the resistive drop of the rotor is the derivative of the stator flux linkage per phase as:

$$v_a - i_a \cdot r_a = \frac{d\lambda_a}{dt} \quad (12)$$

The control structure shown in Fig. 6 can be used to determine the location (ϕ_s) of the rotating flux vector.

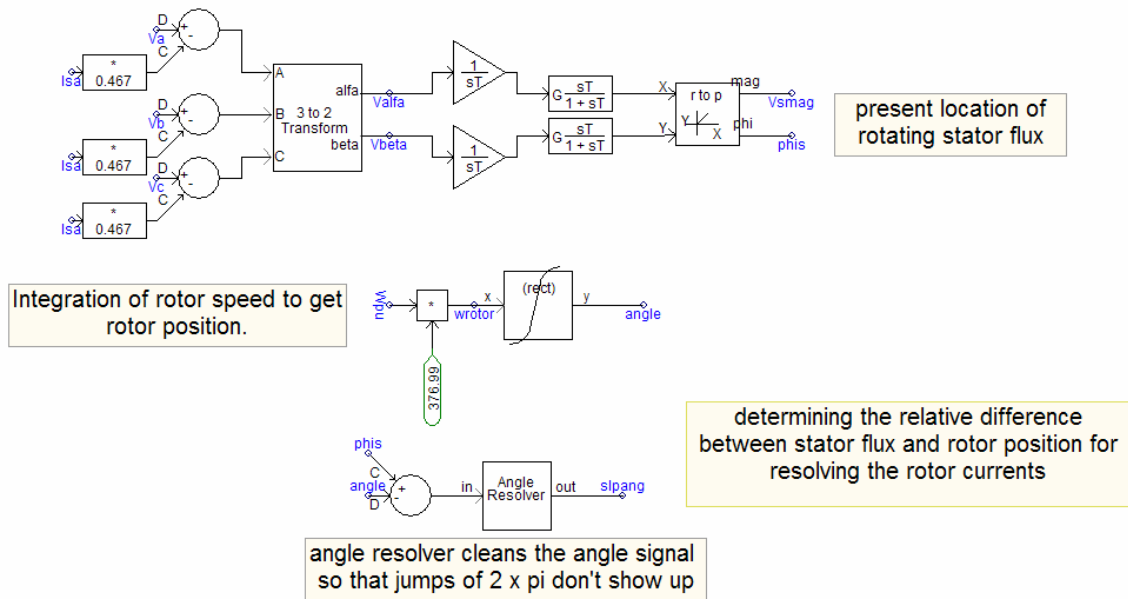

Fig. 6. Control structure for determining the present location of the rotating flux vector

Therefore, the three phase stator voltages after removal of resistive voltage drop are converted into the α, β components as v_{α} and v_{β} , which are orthogonal in the balanced steady state. This transformation is given by:

$$\begin{pmatrix} v_{\alpha} \\ v_{\beta} \end{pmatrix} = \frac{2}{3} \begin{pmatrix} 1 & -\frac{1}{2} & \frac{1}{2} \\ 0 & \frac{\sqrt{3}}{2} & -\frac{\sqrt{3}}{2} \end{pmatrix} \begin{pmatrix} v_a \\ v_b \\ v_c \end{pmatrix} \quad (13)$$

By integrating v_{α} and v_{β} , the α, β components of the stator flux λ_{α} and λ_{β} are calculated and converted to the polar form by:

$$|\lambda| = \sqrt{\lambda_{\alpha}^2 + \lambda_{\beta}^2}, \phi_s = \text{tg}^{-1} \left(\frac{\lambda_{\beta}}{\lambda_{\alpha}} \right) \quad (14)$$

The angle ϕ_s gives the instantaneous location of the stator's rotating magnetic field. In practical control circuits some filtering is required in order to rid the quantities λ_α and λ_β of any residual DC component introduced in the integration process.

Now the rotor itself is rotating and is instantaneously located at the rotor angle of ϕ_r . Thus, with a reference frame attached to the rotor, the stator's magnetic field vector is at location $\phi_s - \phi_r$, referred as slip angle ϕ_{slip} . The instantaneous values for the desired rotor currents can then be readily calculated using the inverse dq transformation, with respect to the slip angle. Once the reference currents are determined, they can be generated using a current reference PWM voltage source converter as shown in Fig. 7.

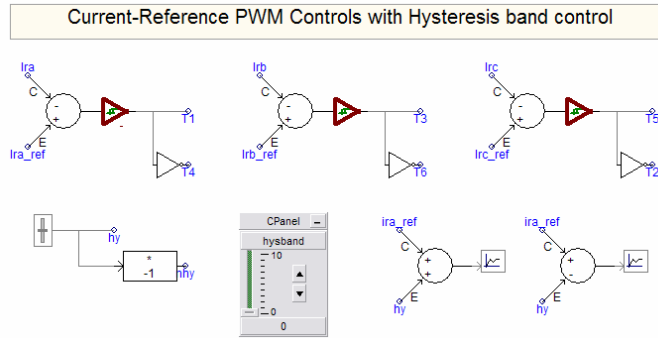

Fig. 7. Generation of reference currents through a current reference PWM voltage source converter

The rotor side voltage source converter requires a DC power supply. The DC voltage is usually generated using another voltage sourced converter connected to the AC grid at the generator stator terminals. A DC capacitor is used in order to remove ripple and keep the DC bus voltage relatively smooth. The grid PWM converter is operated in such a way to keep the DC voltage on the capacitor constant, therefore, the stator side converter is supplying the real power demands of the rotor side converter.

It is possible to control the d axis current by controlling the d -component of the PWM output waveform and the q axis current via the q component. However, this leads to a poor control system response, because attempting to a change in i_d results in a change in i_q . Hence, modifications have to be made to the basic PI controller structure so that a decoupled response is possible, and a request to change i_d changes i_d and not i_q . If a voltage source converter with a constant DC bus voltage is connected to an AC grid through a transformer *i.e.* inductance L and resistance R , it can be shown that:

$$\frac{d}{dt} \begin{bmatrix} i_d \\ i_q \end{bmatrix} = \begin{bmatrix} -\frac{R}{L} & \omega \\ -\omega & \frac{R}{L} \end{bmatrix} \begin{bmatrix} i_d \\ i_q \end{bmatrix} + \frac{1}{L} \begin{bmatrix} v_d - e_d \\ -e_q \end{bmatrix} = \begin{bmatrix} -\frac{R}{L} & 0 \\ 0 & \frac{R}{L} \end{bmatrix} \begin{bmatrix} x_1 \\ x_2 \end{bmatrix} \quad (15)$$

$$x_1 = \frac{v_d - e_d}{L} + \omega \cdot i_d \quad x_2 = \frac{-e_q}{L} - \omega \cdot i_q$$

$$e_d = -Lx_1 + v_d + \omega \cdot L i_d \quad e_q = -Lx_2 - \omega \cdot L i_q$$

The selection of i_{dref} for the grid side converter is for keeping the capacitor voltage at its rated value by adjusting the amount of real power. As $v = v_d$ is the voltage of the AC grid, and because this is chosen as the reference, v_q is by definition zero, e_d and e_q are the d and q components of the generated voltage source converter. Eq. 15 shows that attempting to change i_d using e_d will also cause a change in i_q . If instead, we

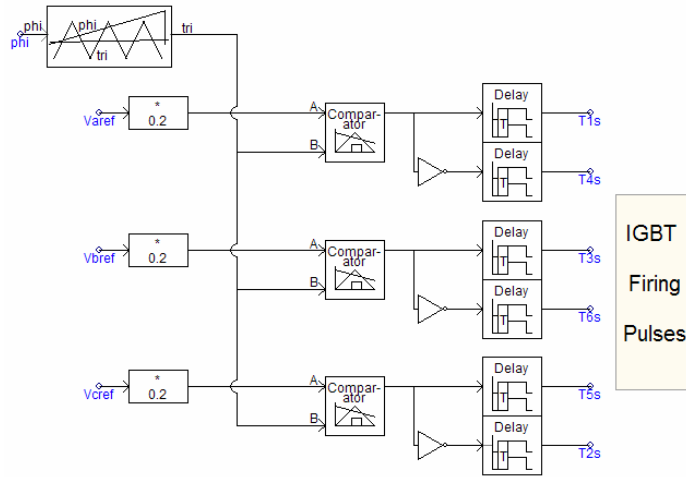

Fig. 11. Control of the IGBT firing pulses for PWM controlling of the converters

The mechanical power and torque extracted from the wind energy are expressed as:

$$P_m = \frac{\rho}{2} \cdot \pi \cdot R^2 \cdot C_p(\lambda, \beta) \cdot v_w^3 \quad T_m = \frac{\rho}{2} \cdot \pi \cdot R^3 \cdot C_t(\lambda, \beta) \cdot v_w^2 \quad (16)$$

where ρ is the air density, R is the radius of turbine blade, v_w is the wind speed and $C_p(\lambda, \beta)$ is the aerodynamic efficiency of the turbine blade. The output energy of wind turbine depends on the method of tracking the peak power points on the turbine characteristics due to fluctuating wind conditions. Optimal power point tracking to capture maximum energy of wind is derived from the power-speed characteristics of the turbine. The role of optimum power tracking system is to maintain the optimal operation. The conventional method is to generate a control law for the target generator power as cubic function of the angular velocity of turbine shaft ω_t as expressed by Eq. 17. The generated power is controlled by field oriented control.

$$P_{opt.} = K_{opt.} \cdot \omega_t^3 \quad K_{opt.} = 0.5 \cdot C_{p \max} \cdot \rho \cdot A \cdot \left(\frac{R}{\lambda_{opt.}} \right)^3 \quad (17)$$

The P_{opt} defines the maximum energy captured and the objective of the tracking control is to keep the turbine operating point to satisfy the maximum captured power as the wind varies. For wind velocities higher than the rated, the captured energy by turbine must be limited by applying pitch control or driving the machine to the stall points. A general method for achieving the optimum operating point tracking is called the current mode control. Given a shaft speed measurement, an electrical torque or electrical power can be imposed on the DFIG after compensation for transmission friction losses:

$$P_{opt.}^* = K_{opt.} \cdot \omega_t^3 - B \cdot \omega_t^2 \quad i_{qr-active}^* = -\frac{2}{3} \frac{L_s}{L_m \cdot v_m} P_{opt.}^* \quad (18)$$

The variable $i_{qr-active}^*$ will be imposed on the control method of the rotor side power converter. When the output power of DFIG falls below the minimum power corresponding to the maximum power point at minimum wind velocity V_l , the system goes to speed mode control. If the power of turbine is greater than P_{min} , the optimum power point tracking is based on the current mode control. If the power of turbine falls below P_{min} , the system goes to speed mode control method. The schematic diagram of this control method is shown in Fig. 12.

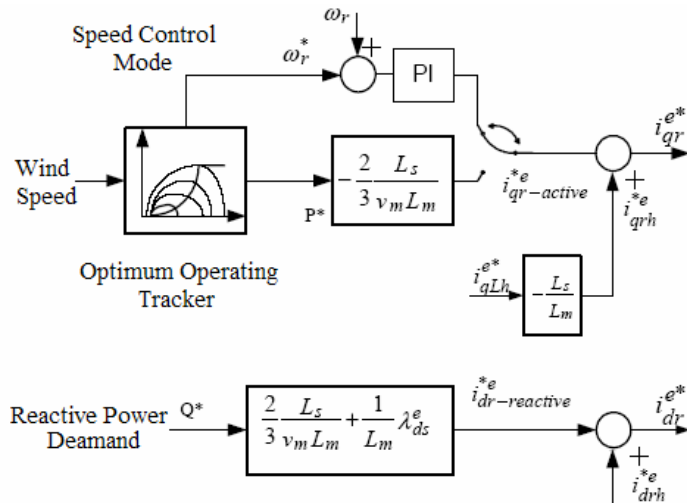

Fig. 12. Schematic of optimum power point tracking mode of DFIG

4. SIMULATION RESULTS

The control scheme of the PSCAD/EMTDC simulated study case for a wind turbine utilizing DFIG was shown in previous section. The stator and rotor current waveforms of the induction generator are shown in Figures 13 and 14, respectively.

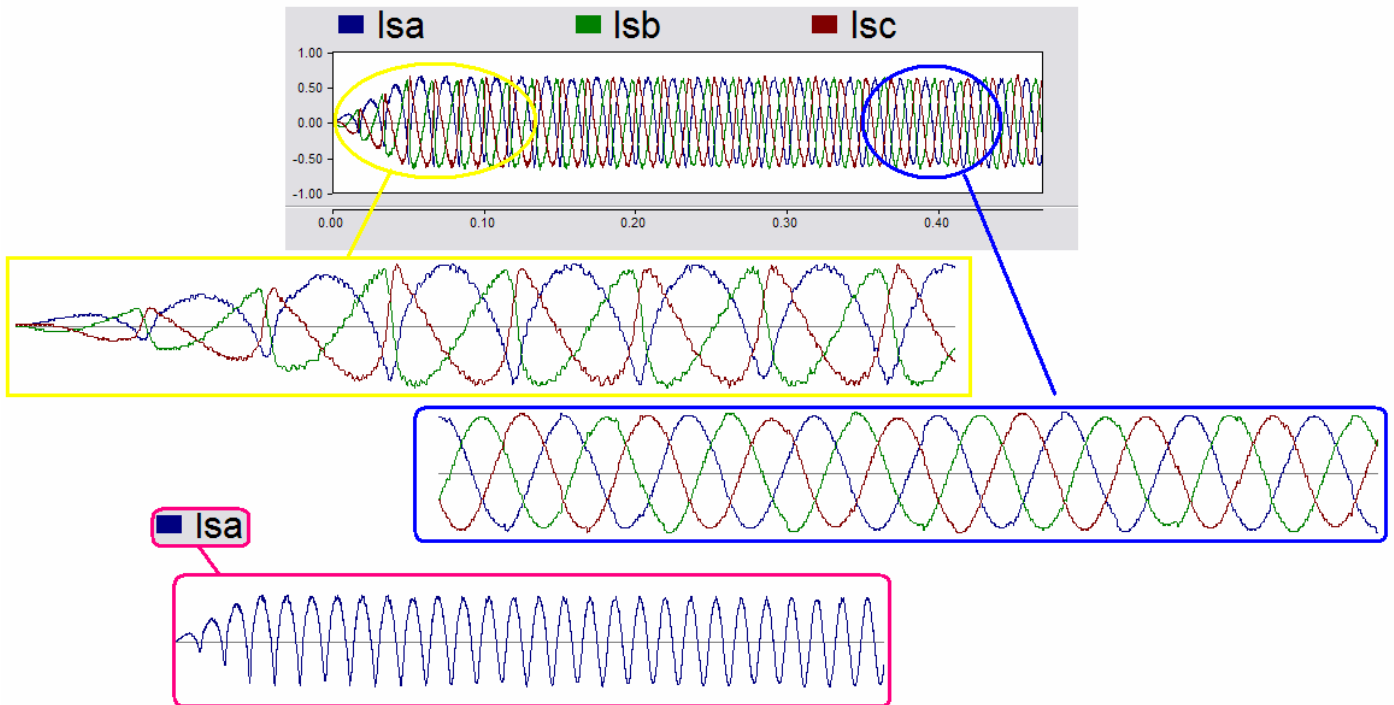

Fig. 13. Stator current waveforms of DFIG case study for wind turbine

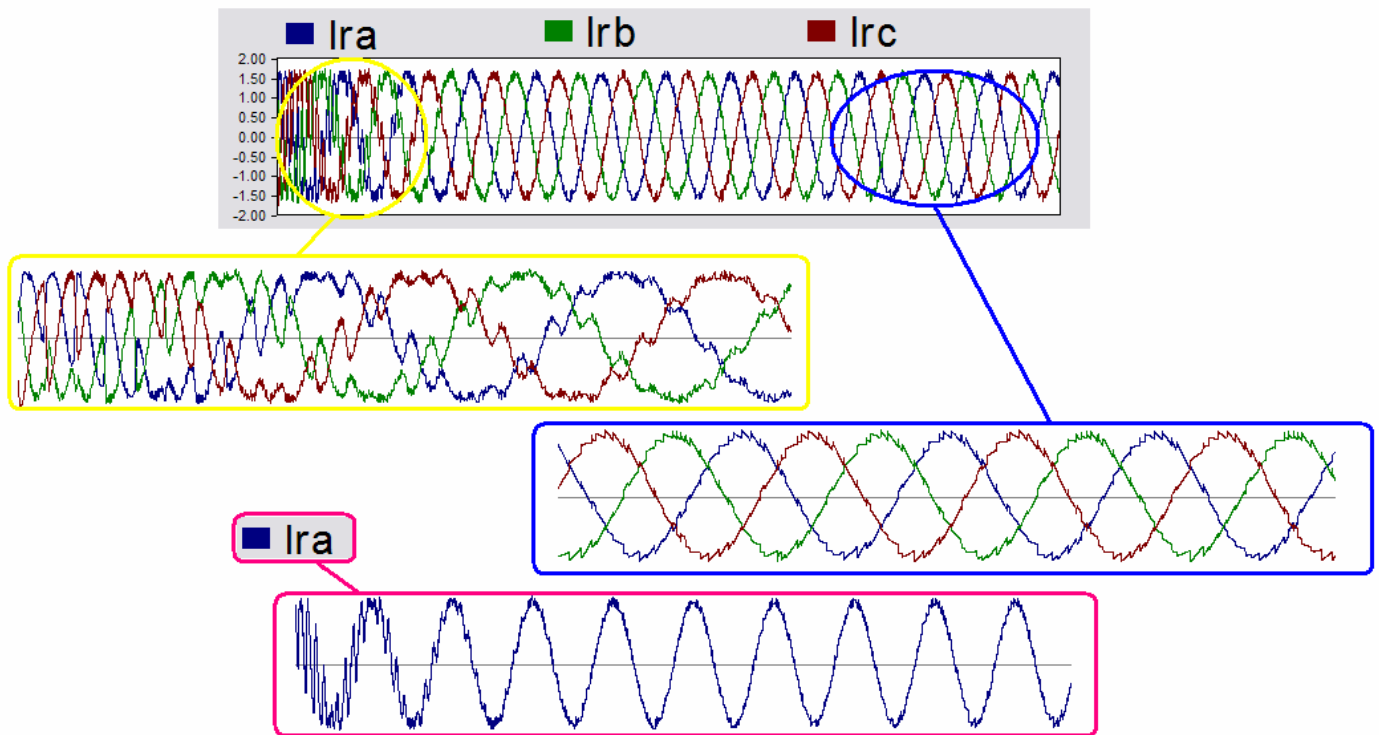

Fig. 14. Rotor current waveforms of DFIG case study for wind turbine

The waveforms of the current reference PWM control of the converter and its waveforms are also shown in Fig. 15.

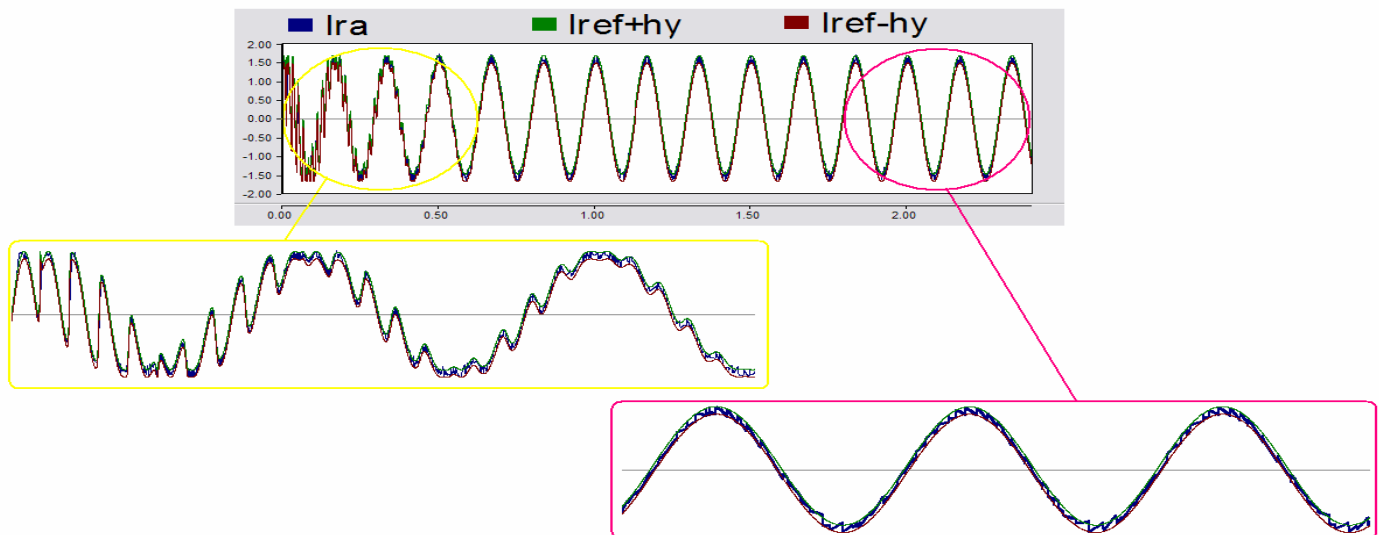

Fig. 15. Waveforms of the current reference PWM control of the converter

The mechanical and electrical torque waveforms of the DFIG run with a wind turbine are shown in Fig. 16 which shows to be almost equal. Also the active and reactive power waveforms at the connection point of the DFIG to the external network are shown in Fig. 17. The nearly constant DC voltage of the DC link between two PWM converters is also shown in Fig. 18.

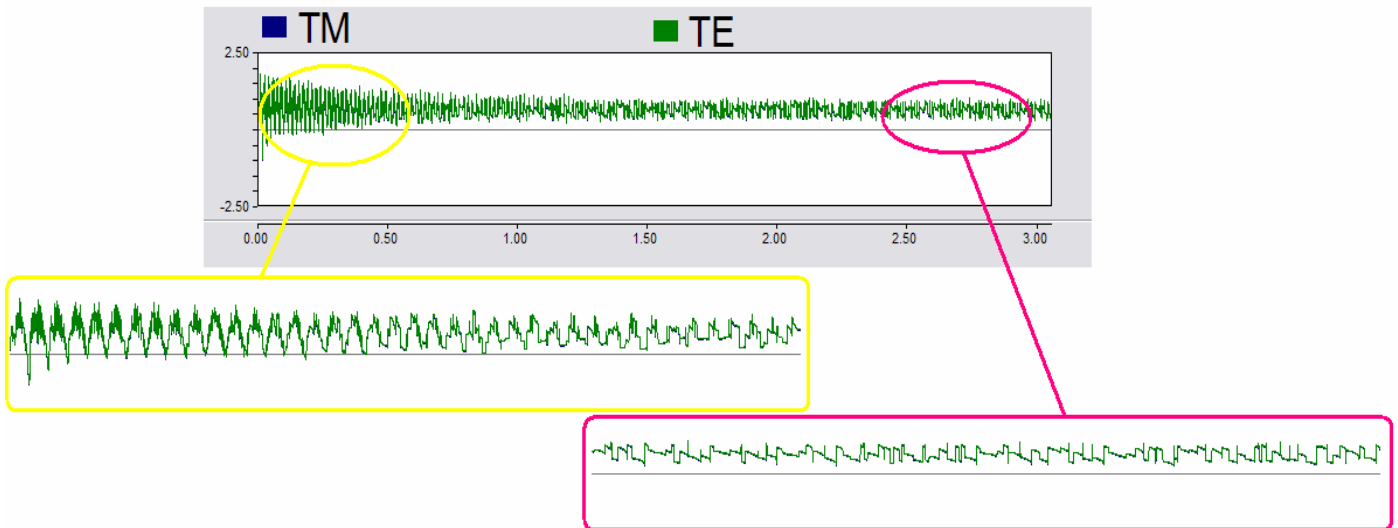

Fig. 16. Mechanical and electrical torque waveforms of the DFIG

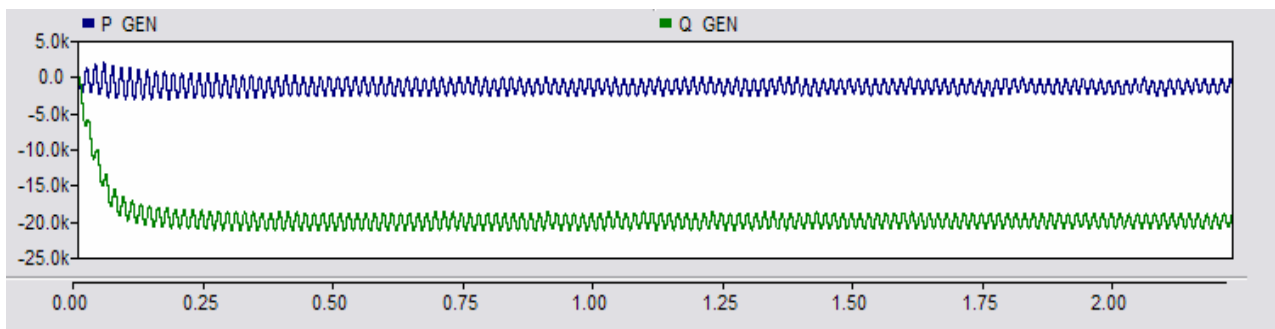

Fig. 17. Active and reactive power waveforms of the DFIG at the connection point to the external grid

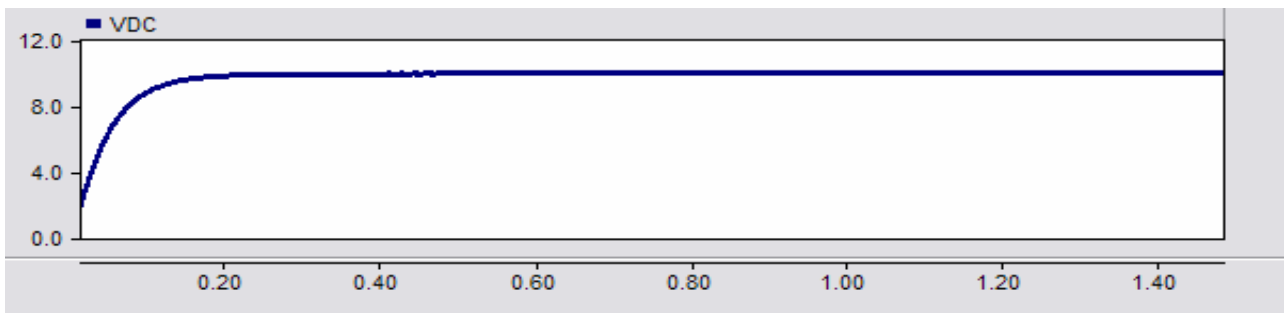

Fig. 18. DC voltage waveform of the DC link between two PWM converters

5. CONCLUSIONS

A Double Fed Induction Generator as the power conversion system in wind turbines is simulated and vector controlled for improving power quality of the grid while injecting the required active power of the system. The system model is developed in the dedicated power electronics and system simulation tool, PSCAD/EMTDC. The model also includes dynamic wind speed fluctuations and control of a soft starter, enabling simulation of the power quality characteristics of the wind turbine. Based on the simulation results, it is proved that the proposed DFIG is capable of simultaneous capturing maximum power of wind energy with fluctuating wind speed and improving power quality, that are achieved by cancelling the most significant and troublesome harmonics of the utility grid. Dynamic power factor correction and reactive power control are the other two significant features of the proposed technology.

6. REFERENCES

- [1] Pooler M.A.: Doubly fed induction machine models for stability assessment of wind farms. Proc. of IEEE Int. PowerTech Conf., 2003, Italy.
- [2] Hansen A.D., Sorensen P., Janosi L., Bech J.: Wind farm modelling for power quality. 27th IEEE Annual Industrial Electronics Society meeting, 2001, pp.1959-1964.
- [3] Abdolhassani M.T., Enjeti P., Toliyat H.A.: Intergrated doubly fed electric alternator active filter, a viable power quality solution for wind energy conversion systems. Proc. of IEEE Int. Conf. of IAS 2004, pp. 2036-2043.
- [4] Schulz D., Hanitsch R.E.: Investigation of the current harmonic parameters of wind energy converters. Proc. of IEEE Int. PowerTech Conf., 2003, Italy.
- [5] Kanellos F.D., Hatziahyriou N.D.: The effect of variable speed wind turbines on the operation of weak distribution networks. IEEE Trans. on Energy Conversion, Vol. 17, 2002, No. 4, pp. 543-548.
- [6] Pena R., Clare J.C., Asher G.M., Doubly fed induction generator using back-to-back PWM converters and its application to variable speed wind energy generation. IEE Proc. on Electr. Power Applications, Vol. 143, 1996, No. 3, pp. 231-241.
- [7] Manitoba HVDC Research Centre, "PSCAD/EMTDC User's Manual Guide", Version 4, 2004.

7. ACKNOWLEDGEMENT

The authors would like to thank the PSCAD support team members at Manitoba HVDC Centre specially Dr. D. Muthumuni, Dr. Z. Zhou and Mr. P. Buchanan for their enormous helpfulness in conducting the project. They also show their best regards for Prof. Ani Gole at the Department of Electrical and Computer Engineering, University of Manitoba for his report on vector control of induction motors.